

(No Model.)

2 Sheets—Sheet 1.

W. W. HULSE.

METAL TURNING LATHE.

No. 302,633.

Patented July 29, 1884.

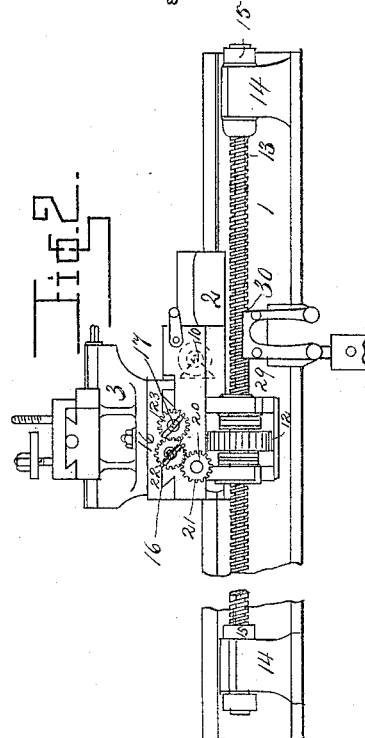
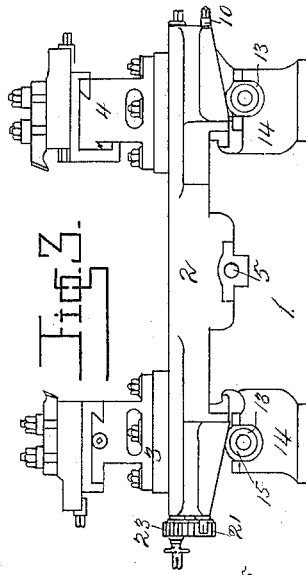
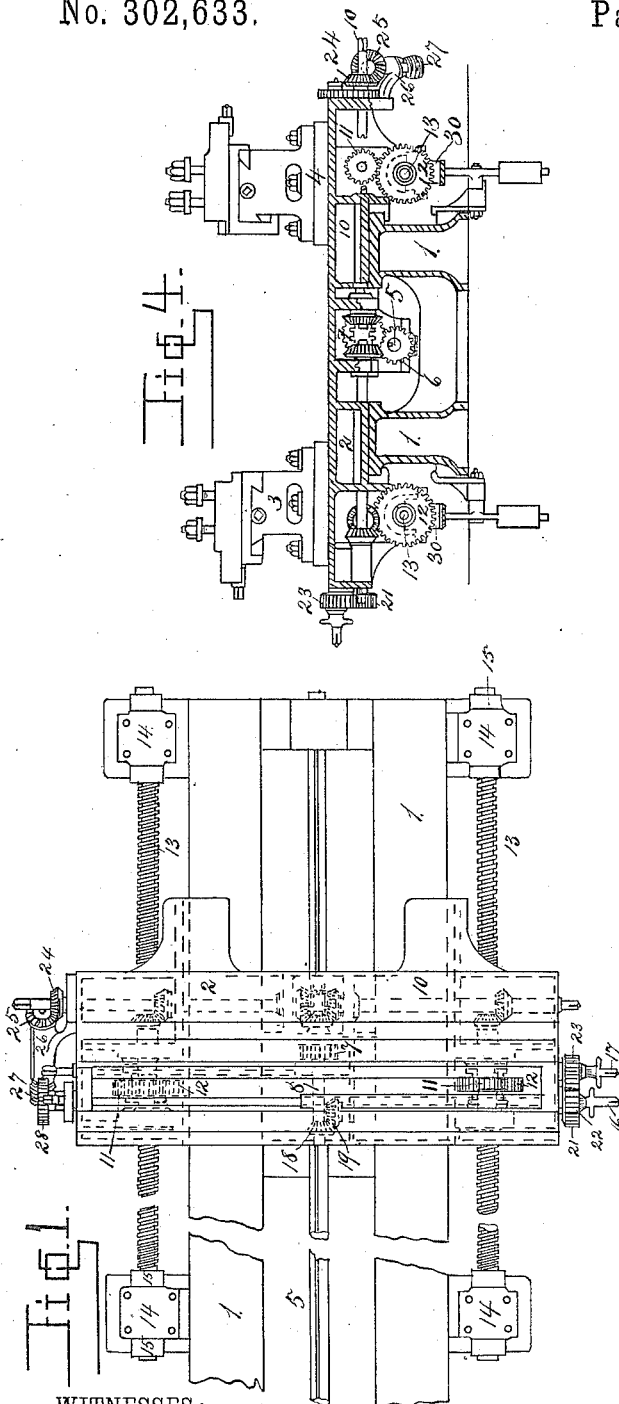

WITNESSES:

J. A. Blackwood
R. G. DuBois

INVENTOR

William Wilson Hulse
 BY
M. M. Doolittle
 ATTORNEY

UNITED STATES PATENT OFFICE.

WILLIAM W. HULSE, OF DIDSBURY, NEAR MANCHESTER, COUNTY OF LANCASTER, ENGLAND.

METAL-TURNING LATHE.

SPECIFICATION forming part of Letters Patent No. 302,633, dated July 29, 1884.

Application filed January 19, 1884. (No model.) Patented in England December 24, 1881, No. 5,664.

To all whom it may concern:

Be it known that I, WILLIAM WILSON HULSE, a subject of the Queen of Great Britain and Ireland, residing at Didsbury, near Manchester, in the county of Lancaster, in the Kingdom of Great Britain and Ireland, have invented new and useful Improvements in Turning and Screw-Cutting Lathes, (for which I have obtained a patent in Great Britain, No. 5,664, bearing date December 24, 1881,) of which the following is a specification.

My invention relates to improvements in turning and screw-cutting lathes; and the chief objects of the improvements are to afford increased facilities for turning and screwing taper work; to enable unusually long lengths of work to be operated upon; to add steadiness to the cutting operations and (by diminishing the frictional resistance of some of the working parts) to lessen the wear and tear and render a larger proportion of the motive power available for the cutting operations. These objects are attained by the mechanism illustrated in the accompanying two sheets of drawings, and described in the following specification.

On Sheet No. 1, Figure 1 is a plan of part of a lathe constructed according to these present improvements; and Figs. 2, 3, 4 are, respectively, a side elevation, an end elevation, and a transverse section, of the same.

In these drawings, 1 is the bed of the lathe. 2 is a carriage, of which each lathe may have one or more.

3 4 are two slide-rests mounted in the carriage 2.

5 is a long shaft carried in bearings in the lathe-bed, driven from the lathe-spindle, and having a long key-groove.

6 is a spur-pinion mounted on the shaft 5, with a sliding feather-key.

7 is another spur-pinion. It is keyed upon a shaft, 8, which is mounted in the carriage 2.

9 is a bevel-wheel on shaft 8, (it is supposed to be removed in Fig. 4,) gearing into two bevel-wheels, as shown. These two bevel-wheels are both mounted upon the cross-shaft 10 and are free to rotate thereon, except when

in gear with the sliding clutch upon the shaft 10, which is shown between them. The shaft 10 may be rotated in either direction, according as the clutch is put in gear with one or other of the two corresponding bevel-wheels. When the clutch is out of gear with both the bevel-wheels, the shaft 10 remains stationary, unless it be rotated by hand.

11 11 are two spur-pinions keyed upon two short longitudinal shafts mounted in the carriage 2 and driven from the shaft 10 by means of two pairs of miter-wheels, as shown. The pinions 11 11 drive two internally-threaded pinions, 12 12. These two pinions when in operation rotate simultaneously upon two guide-screws, 13 13, which are held fast at their ends in clamp-bearings 14 14, and which are adjustable endwise in case of need by means of nuts 15 15. The rotation of the pinions 12 12 upon the guide-screws 13 13 produces a traverse of the carriage upon the lathe-bed.

16 17 are the transverse screws of the slide-rests and are actuated for surfacing work through the shaft 8, by means of a shaft, 20, intermediate bevel-wheels upon the shafts 8 and 20, respectively, and pinions 21, 22, and 23, located, respectively, on the shaft 20 and screws 16 and 17. Each of the transverse screws 16 and 17 is provided with a clutch for engaging it with or disengaging it from its respective pinion, 22 or 23.

24 is a bevel-wheel keyed upon one end of shaft 10. It gears into a bevel-wheel, 25, keyed upon a short worm-shaft, which is mounted in an adjustable swinging bracket, 26, pivoted at right angles to shaft 10. This short shaft is provided with a worm, 27, which gears into a worm-wheel, 28, keyed upon a short shaft through which, by means of a pair of spur-pinions, (one upon this short shaft and the other upon the transverse screw 16,) the guide-screw 16 is rotated and causes its corresponding slide-rest to traverse transversely, while the slide-rest is being traversed longitudinally, together with the carriage 2. These two combined motions enable the lathe to turn objects of a taper form. The degree of taper is regulated by means of a set of change worm-wheels of differing diameters, the angular po-

sition of the swinging bracket 26 being varied to suit the diameter of the worm-wheel employed. The angular position of the swinging bracket may also be adjusted so as to cause the worm 27 to act either on one side or the other of the worm-wheel 28, according to the direction of the taper required.

It will be seen, from the manner in which the carriage 2 is acted upon by the guide-screws, that it is prevented from cross-winding upon the bed of the lathe, and that consequently there is a diminution of frictional resistance and wear and tear, and an increase in the proportion of the motive power available for and in the steadiness of the cutting operations. In lathes (according to my present improvements) which are intended for operating upon work of such length that the guide-screws cannot conveniently be made each in one length, each of them is made in two or more lengths, which meet together end to end, as shown at 29, and are suitably jointed together. In some cases it is more convenient to be able to traverse the slide-rest at the back of the lathe independently of that at the front, and vice versa. In such cases each slide-rest is mounted upon an independent carriage, the carriages being so arranged that they will pass by one another. The arrangement is illustrated on Sheet 2 of the accompanying drawings, in which Fig. 5 is a plan of part of the lathe; and Figs. 6, 7, 8 are respectively a side elevation, an end elevation, and a transverse section of same.

Similar numbers on Sheets 1 and 2 denote similar parts.

Referring to Sheet 2, it will be seen that in the arrangement illustrated each carriage 2 is acted upon by only one guide-screw 13, and that there is a long shaft, 5, in combination with each guide-screw. Each long shaft 5 is provided with two sliding bevel-wheels, *a b*, which are not keyed to the shaft, and which have a sliding clutch, *c*, between them. These two wheels gear into a third bevel-wheel, *d*, keyed upon a short cross-shaft, 29, Fig. 6, as shown most clearly in Fig. 5. The shaft 29 drives another cross-shaft, 30, by means of spur-wheels *e f*, as shown, that upon 30 being provided with a clutch, as shown, for throwing the shaft in or out of gear. This shaft 30 drives a short longitudinal shaft, 31, Fig. 8, by means of bevel-wheels *g h*, as shown; and on the shaft 31 is a spur-pinion, *i*, which

drives the internally-threaded pinion 12, which rotates on the guide-screw 13. Each carriage is fitted with a swinging bracket, 26, and apparatus for producing taper work similar to that already described. The swinging bracket is pivoted concentrically with shaft 29, which drives the tapering apparatus by means of a bevel-wheel, *m*, as shown. In this case the tapering apparatus is used for surfacing also.

It will of course be understood that when this apparatus is used for surfacing, the mechanism for actuating the guide-screw nuts is out of gear.

What I claim is—

1. In a lathe, the bed provided with one or more non-rotating guide-screws, in combination with one or more traveling lathe-carriages, each provided with an internally-threaded pinion adapted to rotate on one of said guide-screws, and mechanism for actuating said pinion or pinions, whereby longitudinal motion is given to said carriage or carriages, substantially as set forth.

2. In a lathe, the bed provided with a non-rotating guide-screw, a lathe-carriage provided with an internally-threaded pinion adapted to rotate on said guide-screw, and mechanism for actuating said pinion, in combination with a transverse screw carried by said carriage, mechanism for actuating said transverse screw, and a slide-rest mounted on the lathe-carriage and actuated by said transverse screw, whereby it is given a lateral motion, substantially as and for the purpose set forth.

3. In a lathe, the lathe-carriage, mechanism for giving longitudinal motion to said carriage, and a slide-rest mounted on said carriage, in combination with a transverse screw carried by the lathe-carriage and adapted to impart lateral motion to said slide-rest, an adjustable swinging bracket mounted on the lathe-carriage, change worm-wheels mounted on said swinging bracket and adapted to actuate the transverse screw, and mechanism for actuating said worm-wheels, whereby the lateral motion of the slide-rest may be regulated, substantially as and for the purpose set forth.

WILLIAM W. HULSE.

Witnesses:

GEO. WM. FOX,
Solicitor, Manchester.

H. C. CARNES,
Patent Agent, No. 10 Norfolk Street, Manchester.